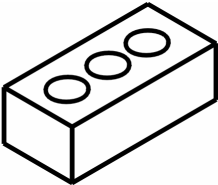
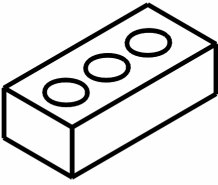
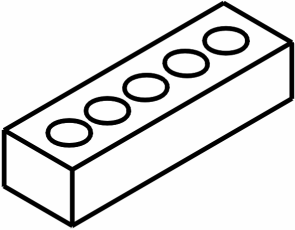
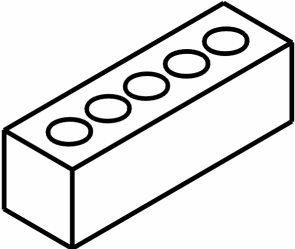
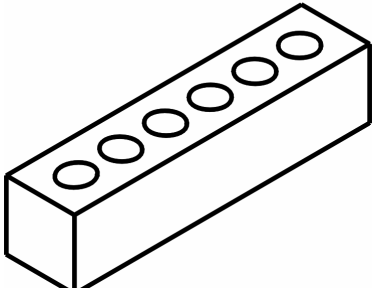

VENEER UNITS

Notes:

- All sizes shown as **Width x Height x Length**. Other sizes may be available from some manufacturers.
- Many special shapes are also available. See your masonry manufacturer for more information.
- Thickness of mortar joints between units can be adjusted slightly by the mason to fit required length/height dimensions.

	Size	Metric (mm)	Imperial (in)
	STANDARD		
	Actual size	90 x 64 x 190	3½ x 2½ x 7½
	Nominal size	100 x 75 x 200	4 x 3 x 8
	Coursing	4c = 300 mm	4c = 12 in
	# of units	66.7 per m ²	6.0 per ft ²
	MODULAR		
	Actual size	90 x 57 x 190	3 ⁵ / ₈ x 2¼ x 7 ⁵ / ₈
	Nominal size	100 x 67 x 200	4 x 2 ² / ₃ x 8
	Coursing	3c = 200 mm	3c = 8 in
	# of units	75 per m ²	6.75 per ft ²
	NORMAN		
	Actual size	90 x 64 x 290	3½ x 2½ x 11½
	Nominal size	100 x 75 x 300	4 x 3 x 12
	Coursing	4c = 300 mm	4c = 12 in
	# of units	44.5 per m ²	4.0 per ft ²
	ECON / SAXON		
	Actual size	90 x 90 x 290	3½ x 3½ x 11½
	Nominal size	100 x 100 x 300	4 x 4 x 12
	Coursing	2c = 200 mm	2c = 8 in
	# of units	33.3 per m ²	3.0 per ft ²
	GIANT		
	Actual size	90 x 90 x 390	3½ x 3½ x 15½
	Nominal size	100 x 100 x 400	4 x 4 x 16
	Coursing	2c = 200 mm	2c = 8 in
	# of units	25 per m ²	2.25 per ft ²

STRUCTURAL UNITS

See Section 1.2.1 for information on structural design

Metric (mm)

Imperial (in)

300 (12") STRUCTURAL

90 x 90 x 290	3½ x 3½ x 11½
140 x 90 x 290	5½ x 3½ x 11½
190 x 90 x 290	7½ x 3½ x 11½
(Nominal 100x300)	(Nominal 4x12)

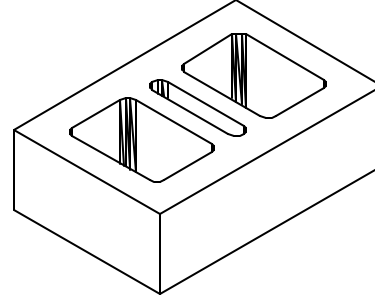

400 (16") STRUCTURAL

90 x 90 x 390	3½ x 3½ x 15½
140 x 90 x 340	3½ x 3½ x 15½
190 x 90 x 390	3½ x 3½ x 15½
(Nominal 100x400)	(Nominal 4x16)

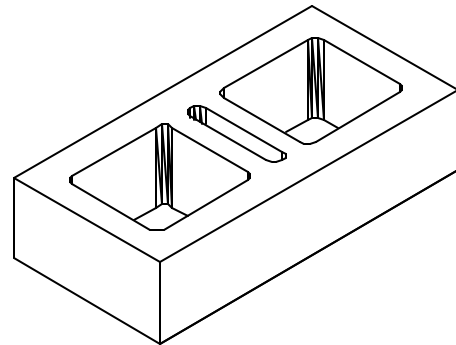

SAMPLE SHAPES

See manufacturer for full range of shapes available.

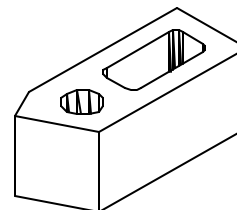
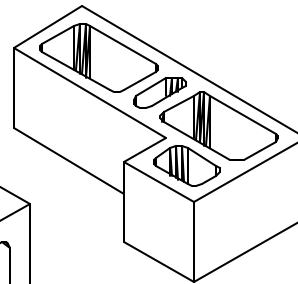
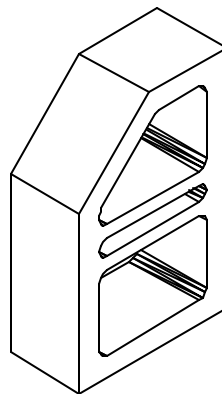
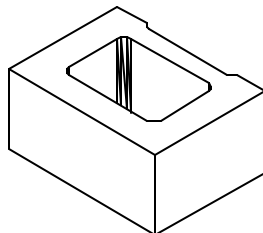
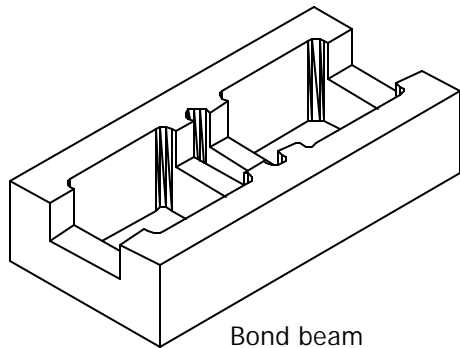

Examples of walls in running bond (half bond) using face brick of differing sizes.

Standard Brick

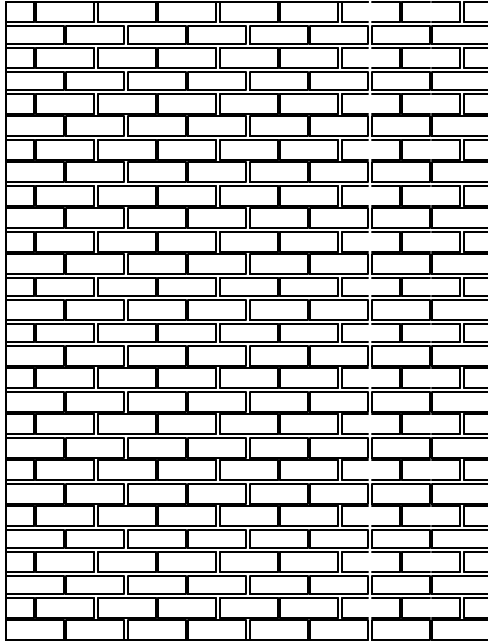

Norman Brick

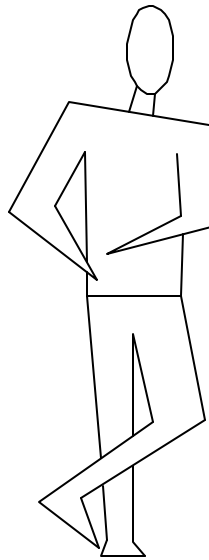
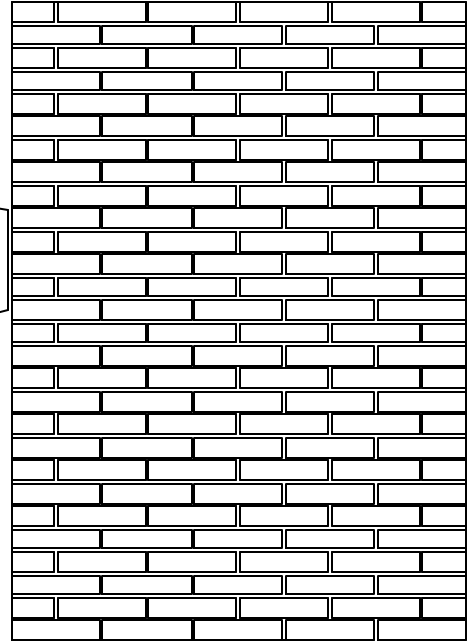

Econ/Saxon Brick

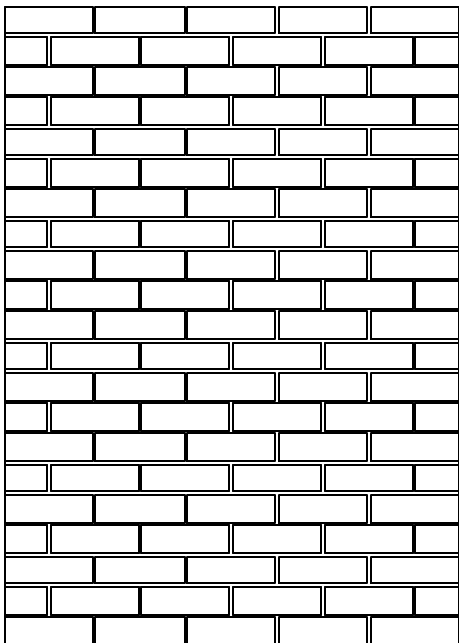

Giant Brick

